

Alternating 4 train siding

See page 2 for hookup details. Ym1

Ym1	Ym2	Ym3	Siding
Red	Any	Any	A
Green	Red	Any	B
Green	Green	Red	C
Green	Green	Green	D

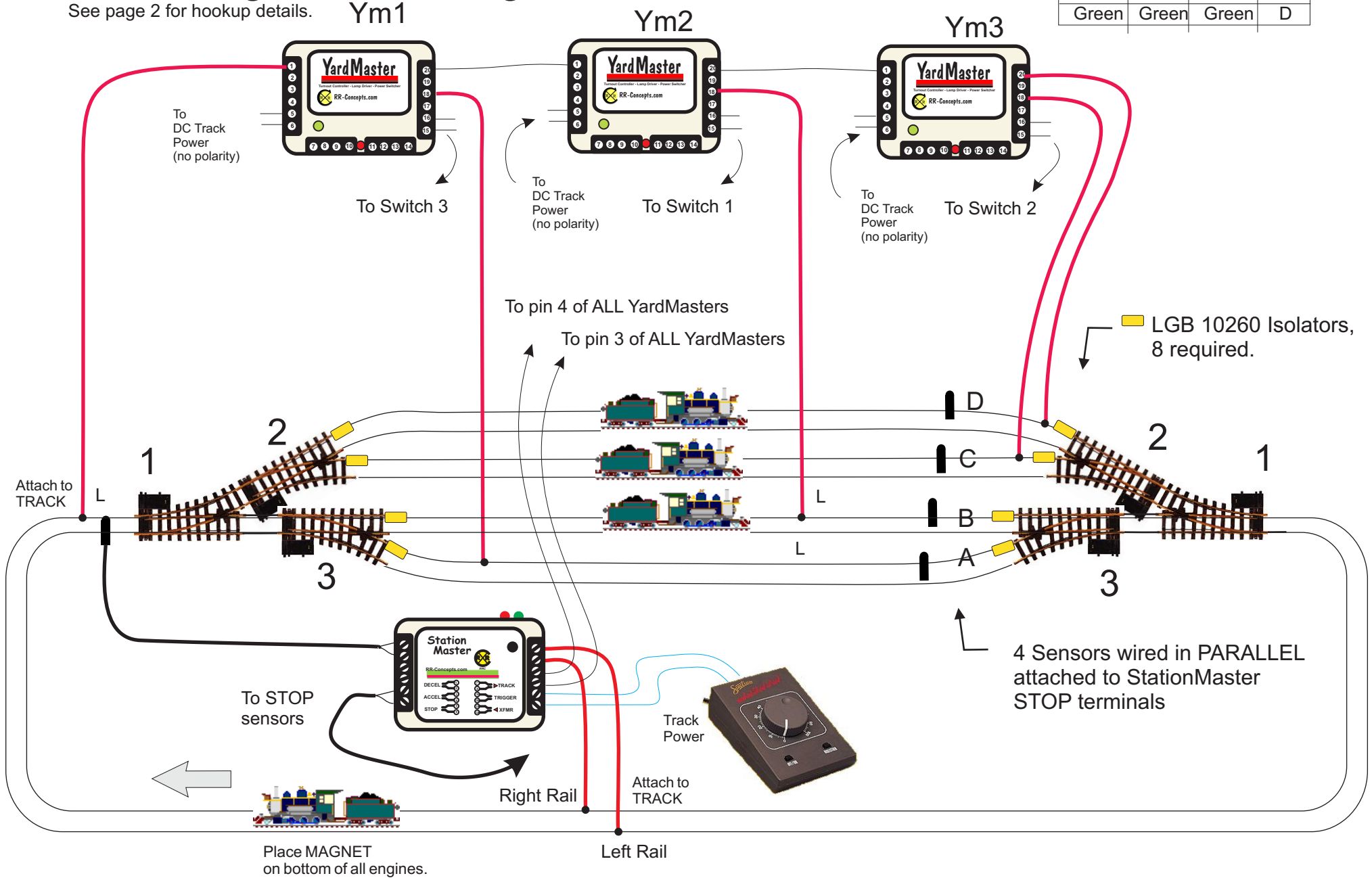

Alternating 4 train siding

Parts required:

StationMaster/Reverser Qty 1
YardMaster: Qty 3
Sensors: Qty 5
Turnouts: Qty 6 ... 3 are powered.
Track Isolators: Qty 8
Magnets: Qty 4, One for each train.

Description:

The 4 Train alternating siding will alternate running 4 trains.

Hookup Description:

YardMaster #1:

Terminal #1 attaches to the left rail of the main line track.
Terminal #3 attaches to StationMaster terminal #9
Terminal #4 attaches to StationMaster terminal #10
Terminals #5 and #6 attach to the DC output of the power pack.
Terminals #15 and #16 attach to switch #3.
Terminal #18 attaches to siding D (left isolated rail).
Terminal #20 attaches to YardMaster 1 terminal #1
Programming: None.

YardMaster #2:

Terminal #1 attaches to YardMaster 1 Terminal #20.
Terminal #3 attaches to StationMaster terminal #9
Terminal #4 attaches to StationMaster terminal #10
Terminals #5 and #6 attach to the DC output of the power pack.
Terminals #15 and #16 attach to switch #1.
Terminal #18 attaches to isolated left rail of siding C.
Terminal #20 attaches to pin 1 of YardMaster #3
Programming: Set for Node #2 (3 blinks)

YardMaster #3:

Terminal #1 attaches to YardMaster 2 Terminal #20.
Terminal #3 attaches to StationMaster terminal #9
Terminal #4 attaches to StationMaster terminal #10
Terminals #5 and #6 attach to the DC output of the power pack.
Terminals #15 and #16 attach to switch #2.
Terminal #18 attaches to isolated left rail of siding B.
Terminal #20 attaches to isolated left rail of siding A
Programming: Set for Node #3 (4 blinks).



StationMaster

Terminals 1 and 2 attach to DECEL sensor. Note: 3 separate DECEL sensors could be used and placed inside of the sidings if desired.

Terminals 5 and 6 attach to STOP sensors wired in parallel in the sidings.

Terminals 7 and 8 attach to the track. 7 is Left rail positive, 8 is Right Rail common.

Terminals 9 and 10 attach to all YardMasters in parallel as shown.

Terminals 11 and 12 attach to input power source. (8 to 20VDC) Set the transformer speed to the desired train speed. (11 is common, 12 is positive)

Programming: Set for 4 trains (5 blinks), Decel rate INFINITE; Lap count as desired; Delay as desired; Accel rate as desired.

Notes:

The direction of the trains is shown in the diagram. Set the transformer direction so that the StationMaster powers up. Set transformer speed to top speed of the train. If the switches do not reliably fire turn up the transformer speed and turn down the top speed dial on the StationMaster to set the top speed of the train.

Each train must carry a magnet to trigger the sensors.

The exit switches can be either powered and wired in parallel with the entry switches or floating with the trains pushing the points.

The LEFT rail of each siding is isolated and attached to a YardMaster.

Right rail is "ground" and is connected to all sidings without isolators.

YardMasters will fire in sequence. Swap the wires to switches as required so that the switch is lined up to the proper siding as shown in the table on page 1.

VERY IMPORTANT!

The StationMaster AND ALL YardMasters MUST obtain power from the same power supply. (transformer) If different power sources are used then damage WILL occur.